

powered by
binder+co

BLU \equiv LINE[®]
SENSOR IDENTIFY(+)

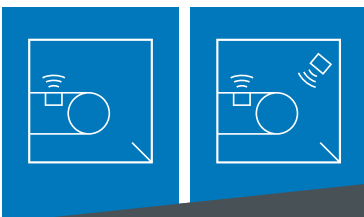

SENSOR IDENTIFY(+)

Sensor-based sorter with induction bar (and colour camera system)

SENSOR IDENTIFY/ IDENTIFY+

powered by
binder+co

BLUELINE[®]
SENSOR IDENTIFY(+)

Acceleration belt

- High throughput thanks to belt speeds of up to 3 m/s and a belt width of 1 m
- Belt scraper for cleaning of the belt surface

Colour camera system

Optical particle detection based on colour and shape
(only SENSOR IDENTIFY+)

Blower unit

Safe discharge of particles using a nozzle bar and automatic pressure control

Vibrating feeder with electromagnetic drive

Optimal homogenisation of the feed material

Induction bar

Particle detection based on electrical conductivity

Compressed air preparation

- Compressed air chamber for covering air peaks
- System is independent of the provided compressed air quality

Automated splitter

Reproducible positioning of the splitter possible by pushing a button

Variable material discharge

- Optimised system layout thanks to free selection of discharge side
- Integrated belt scraper prevents caking

Quick-coupling system

Tool-free installation of the external belt conveyors thanks to folding arms with snap locking

BLUECTRL

- Wireless, decentralised, IT-based control and process control using a tablet (BLUE PANEL)
- All-in-one solution for all BLUELINE system configurations

Total mass	9,600 kg
Dimensions*	6,050 x 2,450 x 2,700 mm
Highest sound pressure level**	71.4 dB(A)
Connected load	3N~400 V / 32 A / 50 Hz

* Without conveying technology and attachments

** 1 m distance from the module surface, empty operating state, without material

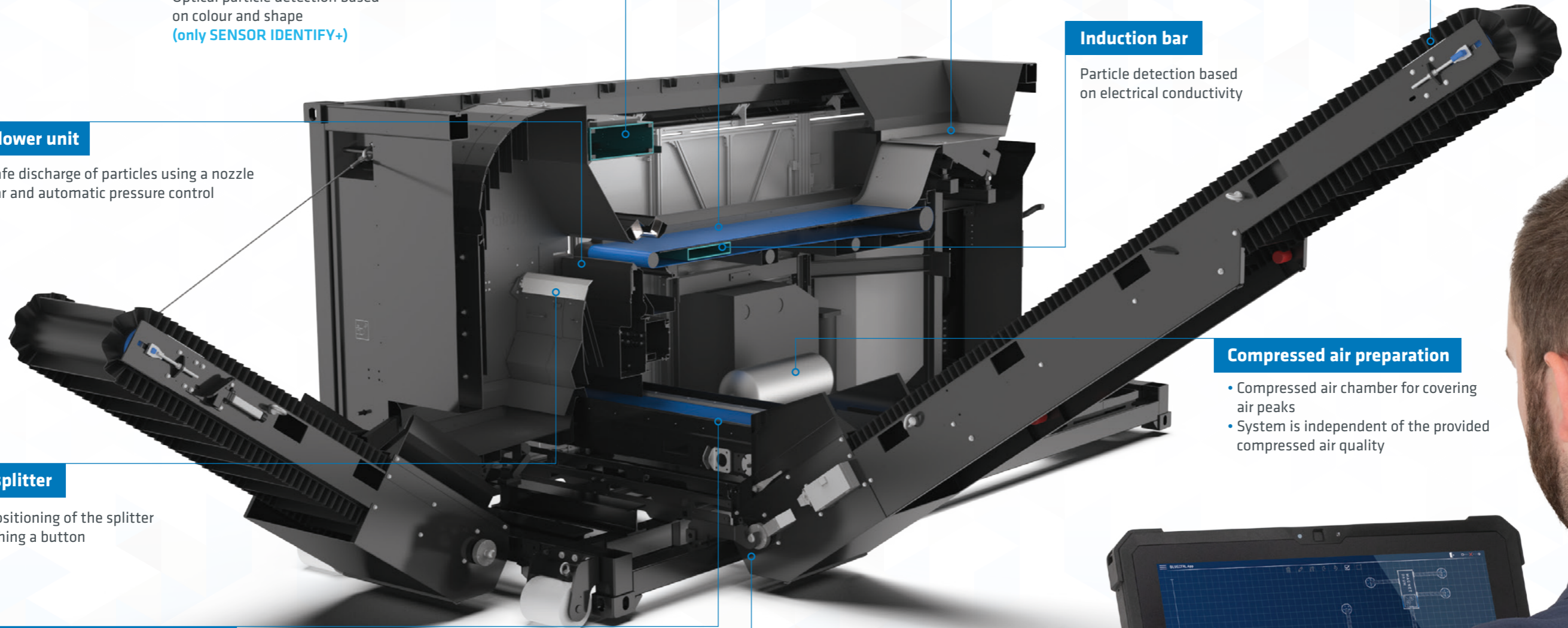

LUKAS SEISENBACHER

Head of Sales & Marketing

M +43 (0) 676 847 172 201

T +43 (0) 7442 93081 201

lukas.seisenbacher@line-technology.com



TOBIAS PECHBÖCK

Sales

M +43 (0) 676 847 172 202

T +43 (0) 7442 93081 202

tobias.pechboeck@line-technology.com



JOHANN FINK

Sales

M +43 (0) 676 847 172 203

T +43 (0) 7442 93081 203

johann.fink@line-technology.com



BERND BREUING

Sales Agent

M +49 (0) 171 97 415 16

T +49 (0) 2361 90 91 866

bernd.breuing@line-technology.com



LINE
technology

LINETECHNOLOGY GmbH

Patertal 20

A-3340 Waidhofen/Ybbs

BLULINE®