

BLUELINE®

SCREEN HEAVY

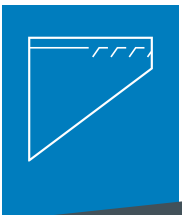

SCREEN HEAVY

Robust coarse particle separator

Screening deck

- Finger screen deck or 3D screen linings for rough pre-screening
- Screen area 1.2 x 2 m

Material slide

Removable material slide for discharge of the coarse parts

Variable material discharge

- Optimised system layout thanks to free selection of discharge side
- Integrated belt scraper prevents caking

Quick-coupling system

Tool-free installation of the external belt conveyors thanks to folding arms with snap locking

Optional hopper feeder attachment

- Brake curtain for dosing of the input material
- Up to 4m³ load

All conveying technology on board

- External belt conveyors available in two different lengths that can be used universally within the BLUELINE system
- High-efficiency drum motors – low-maintenance, durable and reliable!
- Suction hoods to reduce dust emissions available as an option

Corrugated edge belt with cleats

Secure bulk material transport at 35° belt inclination

BLUCTRL

- Wireless, decentralised, IT-based control and process control using a tablet (BLUE PANEL)
- All-in-one solution for all BLUELINE system configurations

Total mass	8,700 kg / with feeder 9,500 kg
Dimensions*	6,050 x 2,450 x 2,700 mm / with feeder 6,050 x 2,450 x 3,360 mm
Highest sound pressure level**	81.2 dB(A)
Connected load	3N ~ 400 V / 32 A / 50 Hz

* Without conveying technology and attachments
** 1 m distance from the module surface, empty operating state, without material

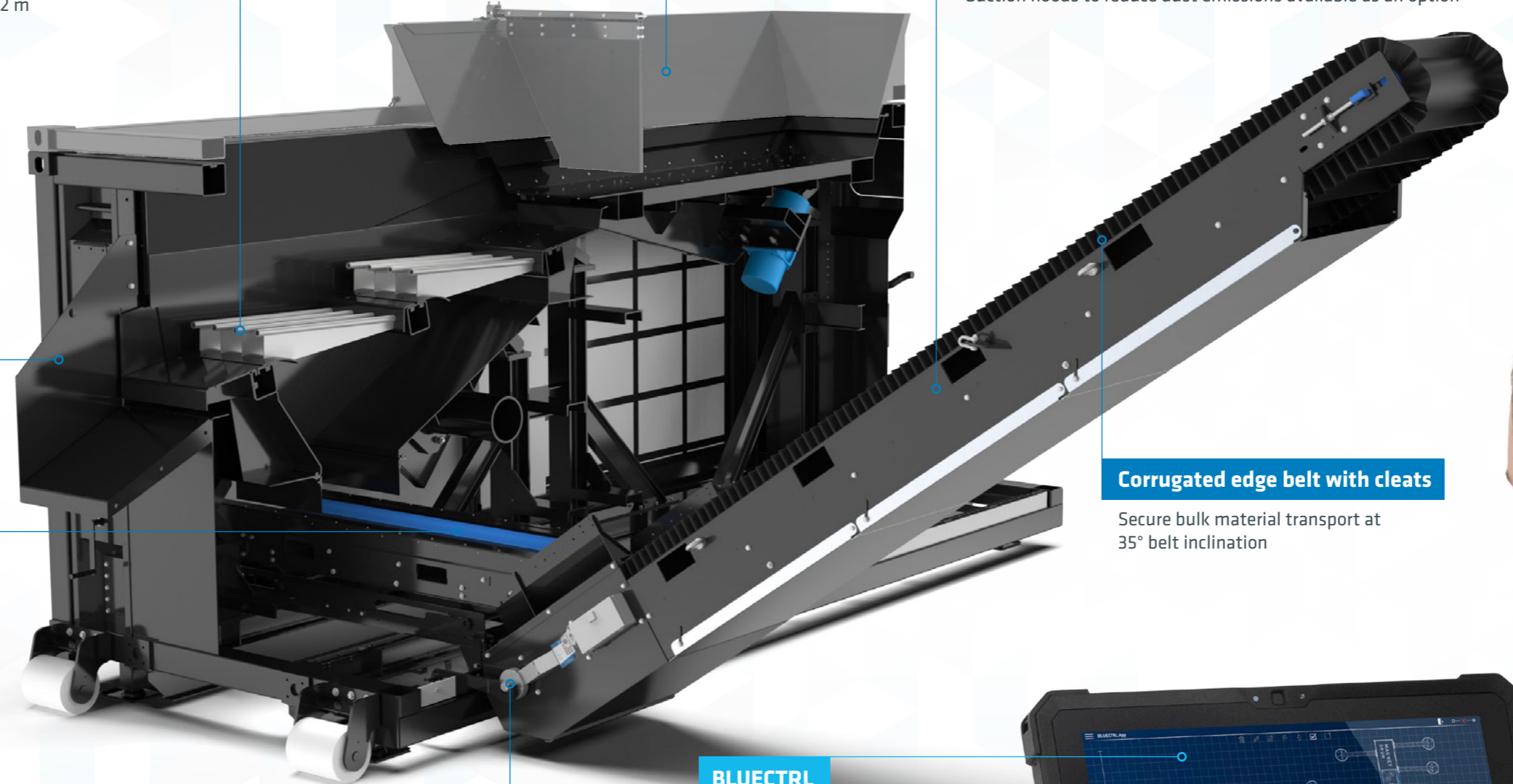



Contact us

www.line-technology.com/contact

03/23 - Design by FALKEmedia.at

LINE
technology

LINETECHNOLOGY GmbH
Patertal 20
A-3340 Waidhofen/Ybbs
+43 (0) 7442 / 930 81
office@line-technology.com

BLU**E****LINE**[®]

aigner
ABSAUGTECHNOLOGIE

ANDRITZ

binder+co

IFE
Material Handling

UNTHA
shredding technology

WESTERIA
MOVING INNOVATION