

BLUELINE[®]
SCREEN DOUBLE

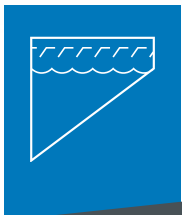

SCREEN DOUBLE

Double-deck linear vibrating screen with 3D screen lining and flip-flow screen deck

SCREEN DOUBLE

BLUELINE®
SCREEN DOUBLE

Variable material discharge

- Optimised system layout thanks to free selection of discharge side
- Integrated belt scraper prevents caking

3D screen deck (top deck)

- Durable 3D screen linings for a wide range of requirements
- Screen area 1.2 x 4 m

Resonance screen deck (bottom deck)

- Highly flexible PU screen mats guarantee nearly clog-free screening
- Screen area 1.2 x 4 m
- Intelligent vibration measurement and screen lining monitoring

Corrugated edge belt with cleats

Secure bulk material transport at 35° belt inclination

All conveying technology on board

- External belt conveyors available in two different lengths that can be used universally within the BLUELINE system
- High-efficiency drum motors – low-maintenance, durable and reliable!
- Suction hoods to reduce dust emissions available as an option

Quick-coupling system

Tool-free installation of the external belt conveyors thanks to folding arms with snap locking

BLUECTRL

- Wireless, decentralised, IT-based control and process control using a tablet (BLUE PANEL)
- All-in-one solution for all BLUELINE system configurations

Total mass	9,600 kg
Dimensions*	6,050 x 2,450 x 2,700 mm
Highest sound pressure level**	77.6 dB(A)
Connected load	3N ~ 400 V / 63 A / 50 Hz

* Without conveying technology and attachments
** 1 m distance from the module surface, empty operating state, without material

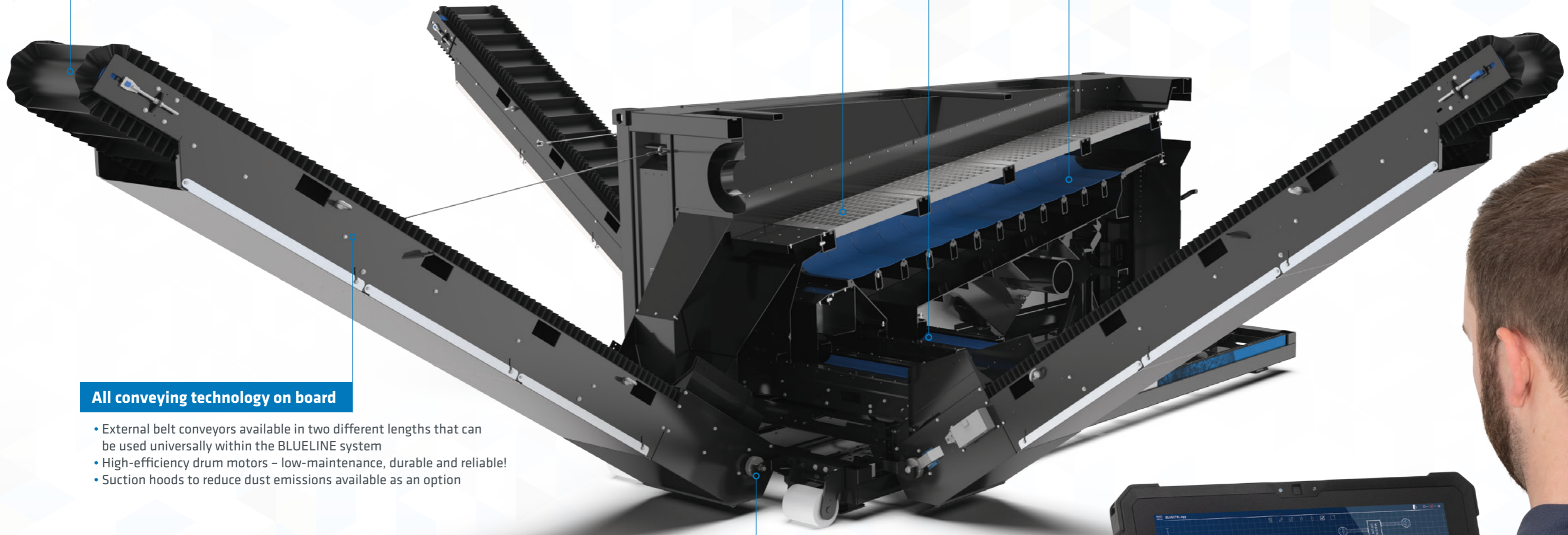

LUKAS SEISENBACHER

Head of Sales & Marketing

M +43 (0) 676 847 172 201

T +43 (0) 7442 93081 201

lukas.seisenbacher@line-technology.com



TOBIAS PECHBÖCK

Sales

M +43 (0) 676 847 172 202

T +43 (0) 7442 93081 202

tobias.pechboeck@line-technology.com



JOHANN FINK

Sales

M +43 (0) 676 847 172 203

T +43 (0) 7442 93081 203

johann.fink@line-technology.com



BERND BREUING

Sales Agent

M +49 (0) 171 97 415 16

T +49 (0) 2361 90 91 866

bernd.breuing@line-technology.com



LINE
technology

LINETECHNOLOGY GmbH

Patertal 20

A-3340 Waidhofen/Ybbs

BLULINE®